

Intelligent Products and the EPC Network

J. P. Brusey

Centre for Distributed Automation and Control
Institute for Manufacturing
Cambridge University

October 5, 2005



**UNIVERSITY OF
CAMBRIDGE**

Outline

- 1 EPC Network
 - Overview

- 2 Pick and Place Demonstrator
 - Using RFID for Perception
 - Transition Model
 - Using an Emulator

EPC Network Overview

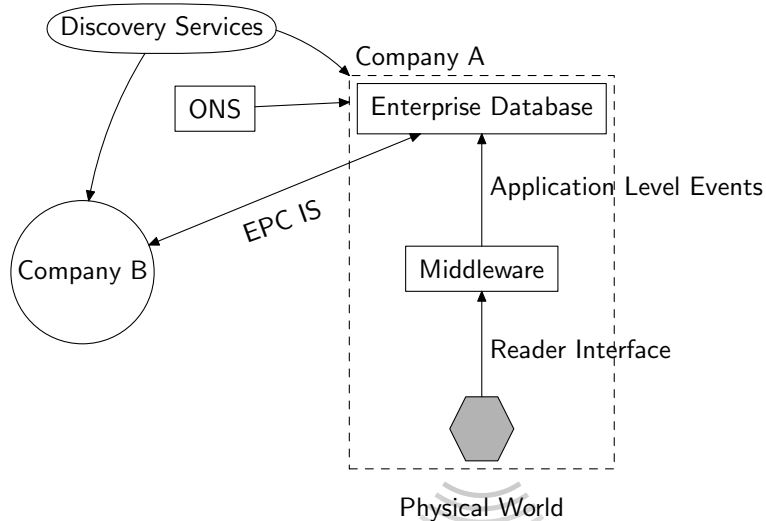

Application Level Events

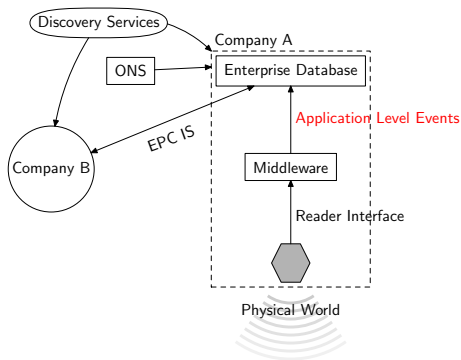

- ALE specification just released
- Defines interface to filtering software
- “Application level” means that application only sees significant events
- Also puts tag read in location context

EPC Information Services

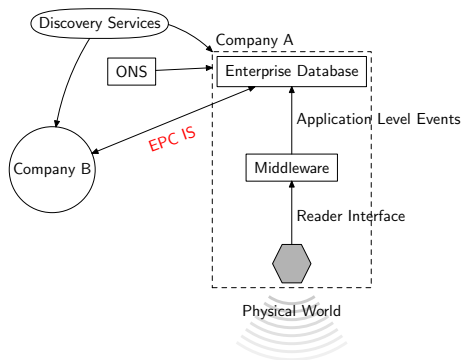

- Provides a B2B interface for talking about individual items
- Based on WSDL and SOAP (and possibly AS2)
- Essentially about *tracking* location
- Also item *attributes* and *associations*
- Also past location *trace*

Object Name Service

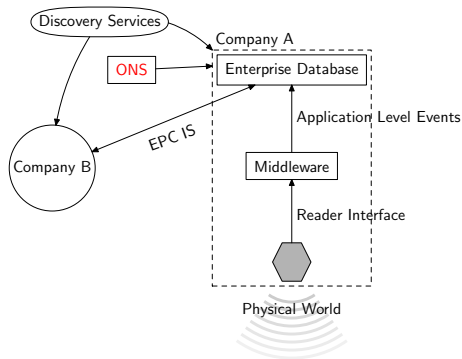

- ONS is running now (it's just a different type of DNS record) and Wal*Mart are using it
- Verisign run root server but EPCglobal own the data
- To query, encode the EPC as a URI
- Returns a URL on the manufacturer's web-site
- ONS is for product class level pointers only

Discovery Services

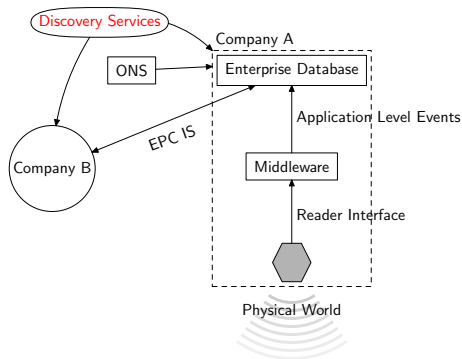

- ONS only provides product level pointers
- But what about products that have data across the supply chain
- We could use forward pointers, but they are fragile
- Another option is a secure discovery service(s) that manages the pointers
- Early days though!

Outline

- 1 EPC Network
 - Overview
- 2 Pick and Place Demonstrator
 - Using RFID for Perception
 - Transition Model
 - Using an Emulator

Laboratory Demonstration



Using RFID for Perception (ALE)

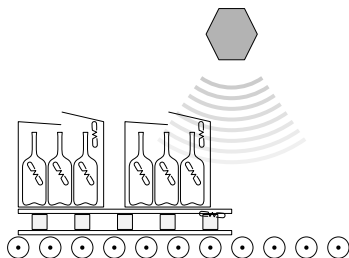

- We used RFID as the main form of perception
- Duplicate removal is best done by estimating “state”
- Aggregate discovery can be done by looking at batches of RFID events
- Prior aggregation information can help detect and correct missed tag reads
- Changes in state provide a trigger for the decision system

Example of aggregate moving past reader

On a conveyor with objects spaced with minimum distance d

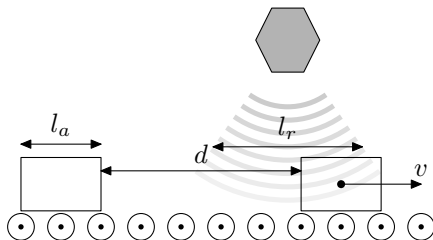

To ensure sufficient spacing to disambiguate aggregates, chose K so that

$$(l_a + l_r)/v < K < (d - l_r)/v$$

Transition Model

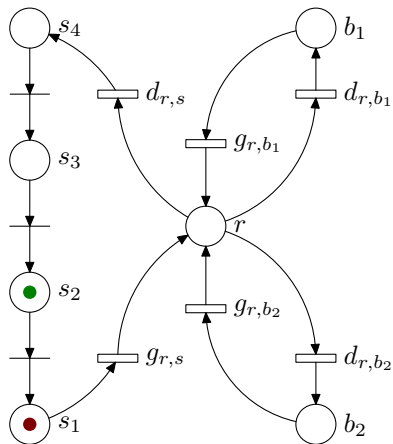

- Part movement can be tracked using a Petri net-based *transition model*
- Parts are “grabbed” $g_{r,s}$ from the base of a stack
- and “dropped” d_{r,b_i} into box b_i
- Timing is critical

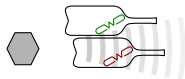

Transition Model

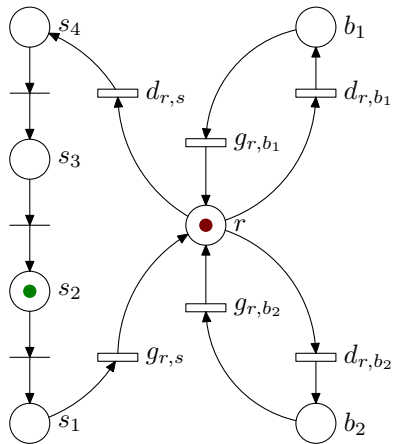

- Part movement can be tracked using a Petri net-based *transition model*
- Parts are “grabbed” $g_{r,s}$ from the base of a stack
- and “dropped” d_{r,b_i} into box b_i
- Timing is critical

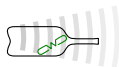

Transition Model

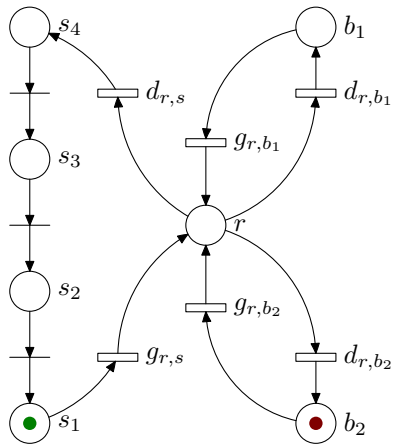

- Part movement can be tracked using a Petri net-based *transition model*
- Parts are “grabbed” $g_{r,s}$ from the base of a stack
- and “dropped” d_{r,b_i} into box b_i
- Timing is critical

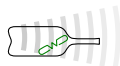

On the Importance of an Emulator

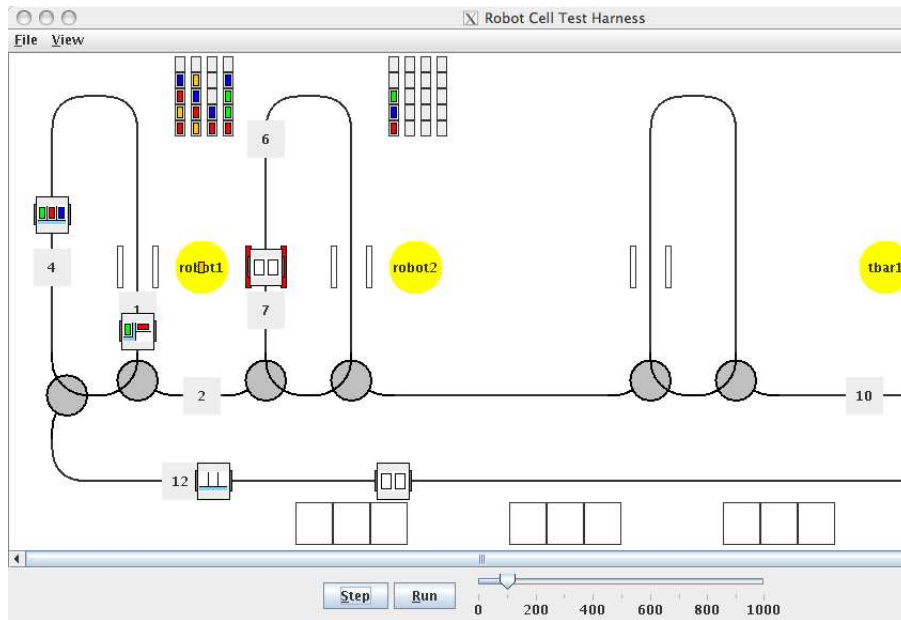

Thanks!

